



BEVERAGE-AIR

Item No. \_\_\_\_\_

Quantity \_\_\_\_\_

FOOD PREPARATION SERIES  
STANDARD TOP

SP SERIES

MODELS:  
SP27  
SP48  
SP60  
SP72

## COMMERCIAL REFRIGERATION EQUIPMENT GENERAL SPECIFICATIONS

### SP SERIES "STANDARD" SANDWICH UNITS

All around prep table with "Cold Air Blanket" assures that product in open containers is kept below 41°F and above freezing. "Cold Air Blanket" eliminates unsanitary defrosting associated with "Cold Wall" construction. Front breathing design feature allows unrestricted placement of unit...e.g. backed against walls and even installed on curbs.

### CABINET CONSTRUCTION

Exterior construction includes heavy-duty stainless steel with #3 finish on front, sides, top, door(s) and grille. Removable hood and insulated lid assembly are made of matching stainless steel. Cabinet back and bottom are constructed of galvanized steel. Interior liner is made of anodized aluminum for superior resistance to corrosion.

Doors are mounted to face of cabinet on gravity hinges permitting them to self close under their own weight. Hinges also allow doors to stay open at 120 degrees and permit easy door removal for service and cleaning if required. A plug in type vinyl magnetic gasket is attached to each door for positive seal. Door handle is made from extruded aluminum with a black anodized finish. It is contoured to permit easy opening of doors with fingers from both top and bottom of handle.

Cabinet insulation is CFC free foamed-in-place polyurethane of two-inch minimum thickness. Six-inch corrosion resistant, adjustable legs are standard. Casters are available as optional. An 8' cord set is provided with 115-volt models.

Cutting board supplied with cabinet is 10" wide constructed of high density white polyethylene plastic. It is readily removable for cleaning. Two epoxy coated steel wire shelves are supplied behind each door. Shelves are adjustable in 1/2" increments. Pans furnished are 4" deep and made of polycarbonate plastic.

### REFRIGERATION

Systems are designed using CFC free R134a refrigerant and capillary tube between condenser and evaporator. Recirculated, forced air from evaporator is moved slightly over and mostly under pans, which are recessed 2" from top of cabinet. Forced air over condenser is drawn through grilles under door(s) as well as the back and bottom of cabinet. Automatic condensate evaporator is provided to eliminate the need of floor drains.



Made in USA  
<http://www.Beverage-Air.com>  
<http://CCR.Carrier.com>



BEVERAGE-AIR  
P.O. Box 5932, Spartanburg, S.C. 29304-5932  
1-800-845-9800 FAX# 864-582-5083

File # \_\_\_\_\_  
 Spec. \_\_\_\_\_



**SP27, SP48, SP60, SP72  
 STANDARD SANDWICH UNITS**

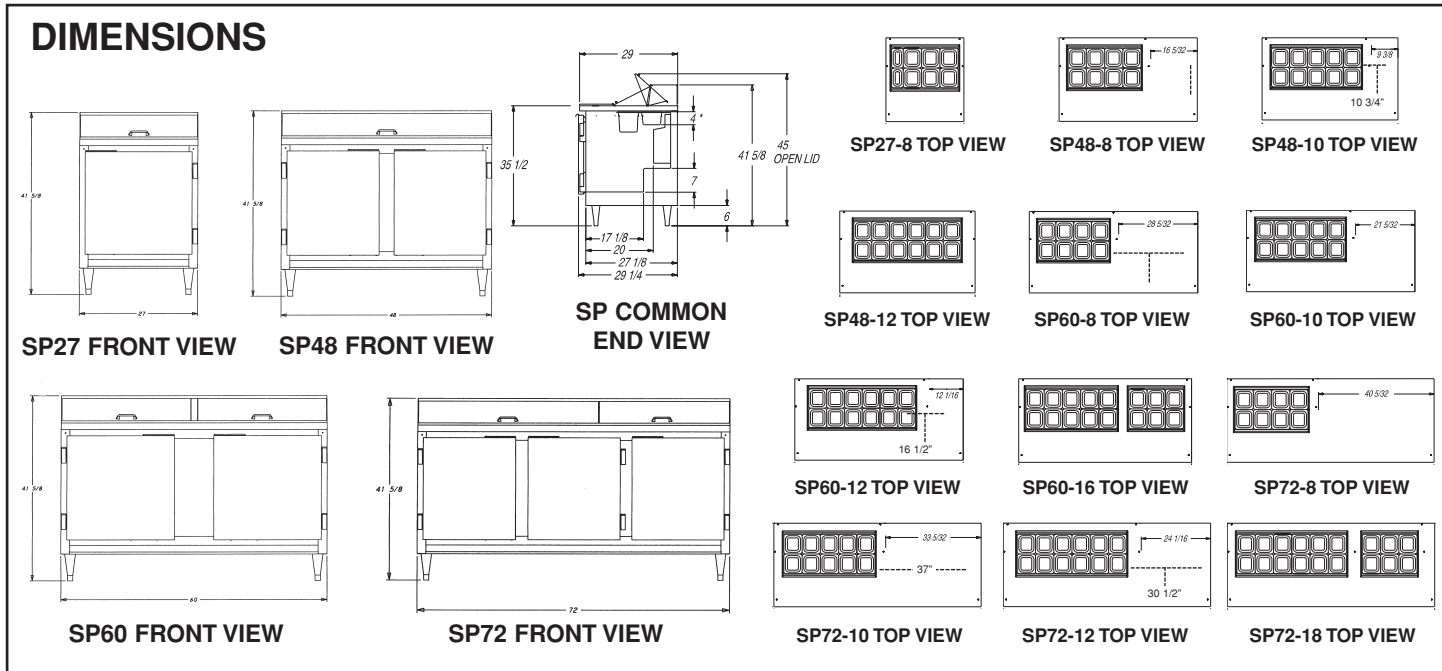

**SPECIFICATIONS**

**FOOD PREPARATION STANDARD SANDWICH UNITS**

MODEL	CRATED WT.	F.O.B.	DOORS	FINISH	CU.FT.	OVERALL EXT. W D H	OVERALL INT. W D H	VOLTS	AMPS	HP	SHELVES	STANDARD PANS 4" DEEP
SP27-8S	179	B	1	S/S	7.3	27"x29 1/2"x41 5/8"	23"x23 1/2"x23"	115	4.0	1/6	2	6-1/6 size/2-1/9 size
SP48-8S	253	B	2	S/S	13.9	48"x29 1/2"x41 5/8"	44"x23 1/2"x23"	115	4.5	1/5	4	8-1/6 size
SP48-10S	255	B	2	S/S	13.9	48"x29 1/2"x41 5/8"	44"x23 1/2"x23"	115	4.5	1/5	4	10-1/6 size
SP48-12S	261	B	2	S/S	13.9	48"x29 1/2"x41 5/8"	44"x23 1/2"x23"	115	4.5	1/5	4	12-1/6 size
SP60-8S	305	B	2	S/S	17.1	60"x29 1/2"x41 5/8"	56"x23 1/2"x23"	115	6.5	1/4	4	8-1/6 size
SP60-10S	307	B	2	S/S	17.1	60"x29 1/2"x41 5/8"	56"x23 1/2"x23"	115	6.5	1/4	4	10-1/6 size
SP60-12S	313	B	2	S/S	17.1	60"x29 1/2"x41 5/8"	56"x23 1/2"x23"	115	6.5	1/4	4	12-1/6 size
SP60-16S	313	B	2	S/S	17.1	60"x29 1/2"x41 5/8"	56"x23 1/2"x23"	115	6.5	1/4	4	16-1/6 size
SP72-8S	347	B	3	S/S	21.5	72"x29 1/2"x41 5/8"	68"x23 1/2"x23"	115	6.5	1/4	6	8-1/6 size
SP72-10S	351	B	3	S/S	21.5	72"x29 1/2"x41 5/8"	68"x23 1/2"x23"	115	6.5	1/4	6	10-1/6 size
SP72-12S	350	B	3	S/S	21.5	72"x29 1/2"x41 5/8"	68"x23 1/2"x23"	115	6.5	1/4	6	12-1/6 size
SP72-18S	366	B	3	S/S	21.5	72"x29 1/2"x41 5/8"	68"x23 1/2"x23"	115	6.5	1/4	6	18-1/6 size

**FEATURES**

- Available in 27", 48", 60", and 72" widths
- 36" working height
- Stainless steel exterior (front and sides)
- Pans, 10" cutting board and 6" legs are standard
- Interior finish is anodized aluminum. Epoxy coated steel shelves are standard
- Removable hood and lid assembly
- Energy efficient forced-air refrigeration system circulates cold air under and slightly over the pans
- Lift-out refrigeration system

**OPTIONS**

- Swivel casters with locks
- Sneeze guard
- Door thermometer
- Factory installed door locks
- Single overshelf
- Double overshelf
- Free standing rod rack (1/2 size sheet pan)



P.O. Box 5932, Spartanburg, S.C. 29304-5932  
 1-800-845-9800    FAX# 864-582-5083  
 ECPC-135451-4/03