



Project _____

Item No. _____

Quantity _____

Model MK62S Tube Fired Gas Fryer

Model MK62S Tube Fired Gas Fryer



STANDARD SPECIFICATIONS

CONSTRUCTION

- Welded tank with an extra smooth peened finish ensures easy cleaning.
- Long lasting, high temperature alloy stainless steel heat baffles are mounted in the heat exchanger tubes to provide maximum heating and combustion efficiency.
- Standing pilot light design provides a ready flame when heat is required.
- Stainless steel front, door, splash back and galvanized steel sides and back.

CONTROLS

- Thermostat maintains selected temperature automatically between 200°F (93°C) and 400°F (190°C).
- Integrated gas control valve acts as a manual and pilot valve, automatic pilot valve, gas filter, pressure regulator, and automatic main valve.
- Gas control valve prevents gas flow to the main burner until pilot is established and shuts off all gas flow automatically if the pilot flame goes out.
- Temperature limit switch safely shuts off all gas flow if the fryer temperature exceeds the upper limit.

OPERATIONS

- Front 1-1/4" NPT drain valve, for quick draining

STANDARD ACCESSORIES

- Tank-stainless steel
- Cabinet-stainless steel front, door, splash back and galvanized steel sides and back
- One tube rack
- Integral Flue Deflector
- Two twin size baskets
- One drain extension
- One drain line clean-out rod
- Removable basket hanger for easy cleaning
- 6" (15.2 cm) Adjustable legs

OPTIONS & ACCESSORIES (AT ADDITIONAL COST)

- 6" (15.2 cm) Adjustable casters
- Tank Cover



MagiKitch'n • P.O. Box 501, Concord, NH 03302-0501 • 509 Route 3A, Bow, NH 03304
603-225-6684 • FAX: 603-225-8497 • www.magikitch'n.com

L10-279 Rev 0 01/07

Printed in the USA



Model MK62S Tube Fired Gas Fryer

Model MK62S Tube Fired Gas Fryer

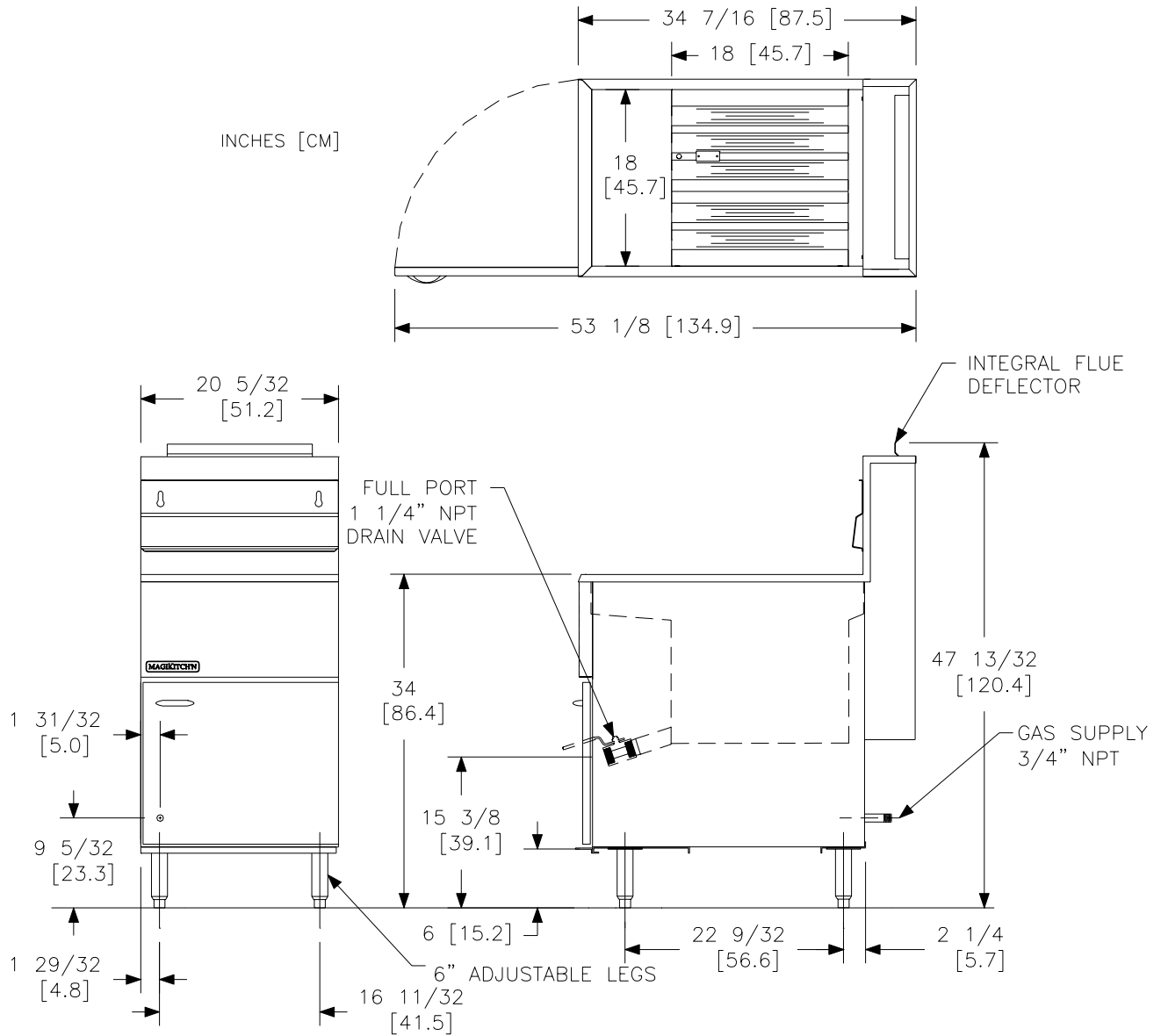

INDIVIDUAL FRYER SPECIFICATIONS

Frying Area	Cook Depth	Oil Capacity	Gas Input Rate / Hr	Burner Pressure Nat	Burner Pressure LP
18 x 18 in (45.7 x 45.7 cm)	3-1/4 - 5 in (8.3 - 12.7cm)	65 - 80 Lbs (29.4 - 36.3 kg)	150,000 BTUs (44 kW) (158 MJ)	4" W.C. (10 mbars / 1 kPa)	10" W.C. (25 mbars / 2.4 kPa)

FRYER SHIPPING INFORMATION (Approximate)

Shipping Weight	Shipping Crate Size H x W x L	Shipping Cube
226 Lbs (102.5 kg)	58 x 22 x 44 in (147.3 x 55.8 x 111.7 cm)	32.5 ft ³ (0.9 m ³)

CLEARANCES

Front min.	Floor min.	Combustible material		Non-Combustible material		Fryer Flue Area
30" (76.2 cm)	6" (15.25 cm)	Sides min.	Rear min.	Sides min.	Rear min.	Do not block / restrict flue gases from flowing into hood or install vent hood drains over the flue.
		6" (15.2cm)	6" (15.2cm)	0"	0"	

SHORT FORM SPECIFICATION

Provide MK62S tube-fired gas fryer. Fryer shall have an atmospheric burner system combined with five stainless steel tubes utilizing high temperature alloy stainless steel baffles. Fryer shall have a deep cool zone; minimum 20% of total oil capacity. Fryer cooking area shall be 18" x 18" (45.7 x 45.7 cm) with a cooking depth of 3 1/4 - 5" (8.3 - 12.7 cm). Heat transfer area shall be a minimum of 700 square inches (4516 sq cm).

TYPICAL APPLICATION

Frying a wide variety of foods in a limited amount of space. Frying that requires a medium volume production rate.



MagiKitch'n • P.O. Box 501, Concord, NH 03302-0501 • 509 Route 3A, Bow, NH 03304

603-225-6684 • FAX: 603-225-8497 • www.magikitch'n.com

L10-279 Rev 0 01/07

Printed in the USA

