

Model MK42S Tube Fired Gas Fryer



STANDARD ACCESSORIES

- Tank-stainless steel
- Cabinet-stainless steel front, door, splash back and galvanized steel sides and back
- One tube rack
- Integral Flue Deflector
- Two twin size baskets
- One drain extension
- One drain line clean-out rod
- Removable basket hanger for easy cleaning
- 6" (15.2 cm) Adjustable legs

OPTIONS & ACCESSORIES (AT ADDITIONAL COST)

- 6" (15.2 cm) Adjustable casters
- Tank Cover

STANDARD SPECIFICATIONS

CONSTRUCTION

- Welded tank with an extra smooth peened finish ensures easy cleaning.
- Long lasting, high temperature alloy stainless steel heat baffles are mounted in the heat exchanger tubes to provide maximum heating and combustion efficiency.
- Standing pilot light design provides a ready flame when heat is required.
- Stainless steel front, door, splash back and galvanized steel sides and back.

CONTROLS

- Thermostat maintains selected temperature automatically between 200°F (93°C) and 400°F (190°C).
- Integrated gas control valve acts as a manual and pilot valve, automatic pilot valve, gas filter, pressure regulator, and automatic main valve.
- Gas control valve prevents gas flow to the main burner until pilot is established and shuts off all gas flow automatically if the pilot flame goes out.
- Temperature limit switch safely shuts off all gas flow if the fryer temperature exceeds the upper limit.

OPERATIONS

- Front 1-1/4" NPT drain valve, for quick draining



Model MK42S Tube Fired Gas Fryer

Model MK42S Tube Fired Gas Fryer

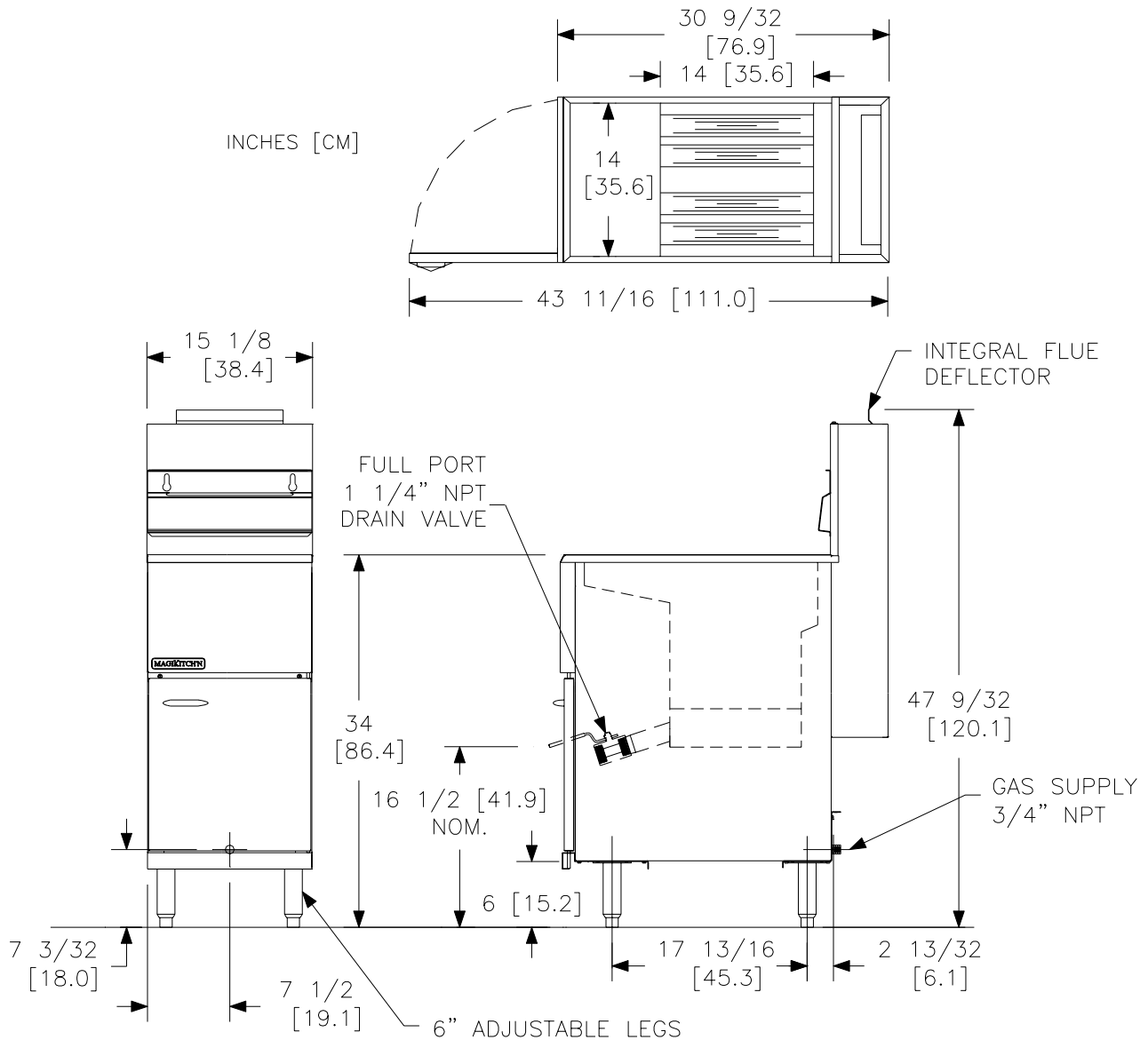

INDIVIDUAL FRYER SPECIFICATIONS

Frying Area	Cook Depth	Oil Capacity	Gas Input Rate / Hr	Burner Pressure Nat	Burner Pressure LP
14 x 14 in (35.6 x 35.6 cm)	4 - 6 in (10.2 - 15.2cm)	40 - 45 Lbs (18 - 20 kg)	115,000 BTUs (31.3 kW) (112 MJ)	4" W.C. (10 mbars / 1 kPa)	10" W.C. (25 mbars / 2.4 kPa)

FRYER SHIPPING INFORMATION (Approximate)

Shipping Weight	Shipping Crate Size H x W x L	Shipping Cube
181 Lbs (82.1 kg)	36 x 19 x 46 in (116.8 x 48.3 x 91.4 cm)	18.2 ft ³ . (0.5m ³)

CLEARANCES

Front min.	Floor min.	Combustible material		Non-Combustible material		Fryer Flue Area
30" (76.2 cm)	6" (15.25 cm)	Sides min.	Rear min.	Sides min.	Rear min.	Do not block / restrict flue gases from flowing into hood or install vent hood drains over the flue.
		6" (15.2cm)	6" (15.2cm)	0"	0"	

SHORT FORM SPECIFICATION

Provide MK42S tube-fired gas fryer. Fryer shall have an atmospheric burner system combined with four stainless steel tubes utilizing high temperature alloy stainless steel baffles. Fryer shall have a deep cool zone; minimum 20% of total oil capacity. Fryer cooking area shall be 14" x 14" (35.6 x 35.6 cm) with a cooking depth of 4 - 6" (10.2 - 15.2 cm). Heat transfer area shall be a minimum of 575 square inches (3,709 sq cm).

TYPICAL APPLICATION

Frying a wide variety of foods in a limited amount of space. Frying that requires a medium volume production rate.



MagiKitch'n • P.O. Box 501, Concord, NH 03302-0501 • 509 Route 3A, Bow, NH 03304

603-225-6684 • FAX: 603-225-8497 • www.magikitch'n.com

L10-280 Rev 1 01/07

Printed in the USA

