

Quest

GAS COOKING EQUIPMENT

The Quest Char Broiler has been designed to deliver better food taste and appearance. Steaks, chops, ribs, chicken, fish, and hamburgers are all charbroiled more quickly and efficiently with better tasting results.

The range-matching profile lines up perfectly with other Quest equipment to provide a productive, sanitary, and attractive cooking arrangement. The gleaming stainless steel exterior makes the Quest Char Broiler ideal for display kitchens where customers watch the chef in action.

THE SECRET TO BETTER BROILING

The secret to better broiling is faster searing. The high performance Quest Char Broiler quickly seals in the juices and nutritional value of all types of food. The heavy duty cast iron burners, "Infra-Red" stainless steel radiants, 4" spaced burners, and individual air deflectors have all been engineered to deliver more heat than competitive equipment.

REDUCED COOKING TIME AND BETTER TASTE

More heat means less cooking time and less smoke to taint the natural flavour of food.

The design of Quest's tilting grid works to minimize flare-ups which can rob food of its taste-tempting moisture and impart a bitter taste to meat.

The grid rods are ideally spaced to give broiled food an attractive "branded" appearance. They also reduce breakage loss by providing perfect support for hamburger patties. When operated flat, they are ideal for cooking sausages and ribs.

INCREASED PRODUCTIVITY

Quest burners heat more quickly, are non-clogging, and are individually controlled and spaced to give a consistent, even, and infinitely adjustable heat. Even inexperienced cooks find the Quest Char Broiler easy to use.

You get charbroiled flavour and appearance without the high fuel and labour costs associated with charcoal and other solid fuels. The dangers of fire from excessive flare-up are also minimized.

The fat run-off on the steel grid rods reduces smoke and clean-up, and enables the broiler to be used in every type of operation.

It all adds up to more cooking capacity in less space at a lower cost.



CHAR BROILER

MODEL QB

- **RANGE MATCHING: LOW PROFILE / MODULAR DESIGN**
- **STAINLESS STEEL RADIANTS: CHARBROILED FLAVOUR AND APPEARANCE WITHOUT CHARCOAL**
- **HIGH PERFORMANCE: HOTTER THAN COMPETITIVE BROILERS**
- **EASY TILT GRID: MINIMIZES FLARE-UPS AND INCREASES COOKING FLEXIBILITY**
- **DISMANTLES EASILY FOR CLEANING**
- **AVAILABLE IN 4 MODELS (24", 32", 40" AND 48" WIDTH) WITH STAINLESS STEEL FRONT AND LINER, SEAMLESS SIDES, HIGH INSULATED SPLASHGUARDS, HEAVY DUTY CAST IRON BURNERS, AND OPTIONAL CAST GRIDS**

"The Quest for the Best Ends at Quest"

MODEL	WIDTH (mm)	DEPTH (mm)	BODY HEIGHT (mm)	BTU's	GAS LINE	GRID SIZE		SHIPPING WT	
						SQ IN	SQ CM	LBS	KGS
QB 24	24" (610)	31" (790)	8½" (216)	60,000	¾" (19)	476	(3070)	215	(98)
QB 32	32" (815)	31" (790)	8½" (216)	90,000	¾" (19)	662	(4270)	275	(125)
QB 40	40" (1020)	31" (790)	8½" (216)	120,000	¾" (19)	848	(5470)	330	(150)
QB 48	48" (1220)	31" (790)	8½" (216)	150,000	¾" (19)	1035	(6680)	390	(175)

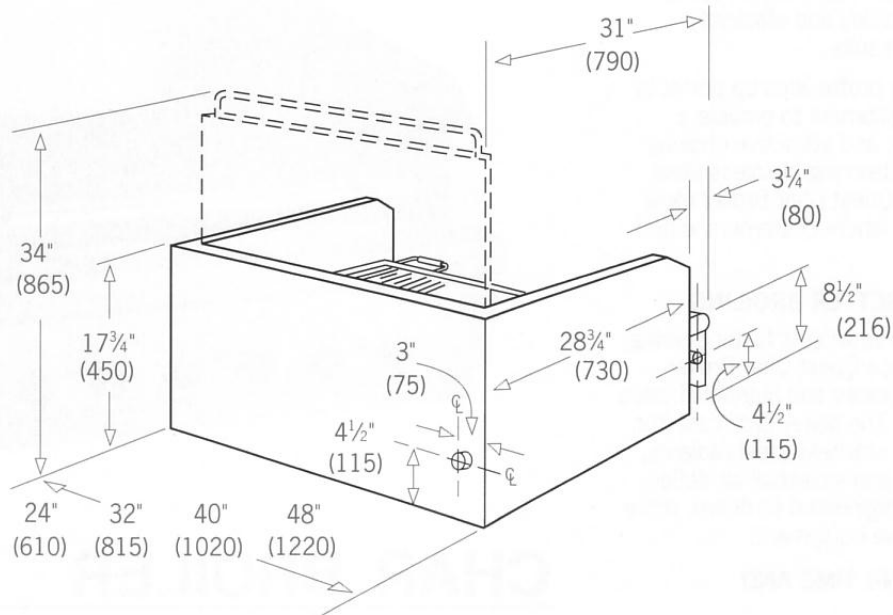

OPTIONAL BASE

The low profile (8½" - 216 mm) of the Quest Char Broiler frees up valuable storage space beneath the unit. All varieties of Quest modular bases can be used with QB series broilers.

An optional refrigerated base can be supplied to ensure that a fresh supply of broiler menu items are always close at hand. The base unit is available with drawers and/or doors to fit all sizes of broilers.

CLEANING AND MAINTENANCE

Most interior and exterior surfaces including front panel, splashback and inside liner are stainless steel. The unit dismantles easily for cleaning. The grid can be lifted off, or tilted upright at the back. The stainless steel radiants are removable and have been designed to protect the burners from dripping grease.

Grease run-off from the grid is collected in a slide-out grease can which is well shielded from direct heat. The grease level is always visible and the can is easily emptied.

INSTALLATION NOTES

- Specify natural gas or propane
- Unit requires 6" (150 mm) clearance from combustible walls at back and 3" (75 mm) at sides.
- ¾" (19 mm) gas connection at rear (ideal for gas hose connection)
- 27" (685 mm) clearance required in front for removal of grease container.

NOTE: Dimensions shown are accurate at time of printing but subject to change without notice. If sizes are critical, consult your Russell representative or the factory.



Quest METAL PRODUCTS LIMITED

949 Erin St., Winnipeg, Manitoba R3G 2W6
Tel: (204) 786-2403 Fax: (204) 783-7598

Distributed in Canada by:

RUSSELL Food Equipment

Victoria / Vancouver / Edmonton / Calgary / Regina
Saskatoon / Winnipeg / Thunder Bay / Sault Ste. Marie
Toronto / London / Windsor / Ottawa / Montreal / Halifax

A3 133 393

PRINTED IN CANADA