

Quest

GAS COOKING EQUIPMENT

MESQUITE



CHARCOAL

HARDWOOD

"The Flavour's in the Drawer"

MODEL QBD "FLAVOURING" CHAR BROILER

- OBTAIN THE FLAVOURING RESULTS OF SOLID FUEL BROILERS WITHOUT THE MESS, HIGH COST OF OPERATION OR NEED FOR SPECIAL VENTILATION
- SIMPLY PULL OUT THE DRAWER FOR EASY ACCESS TO THE FLAVOURING TRAY
- HIGH PERFORMANCE DESIGN FOR FAST SEARING – SEALS IN THE JUICES TO MAXIMIZE NUTRITIONAL VALUE AND TEXTURE
- BROIL STEAKS, SEAFOOD, FISH, POULTRY, ETC., TO PERFECTION
 - ** ALL AT THE SAME TIME IF REQUIRED **
- BURNERS ON 4" SPACING, EACH WITH INFINITE GAS CONTROL – ENSURES DESIRED COOKING TEMPERATURES AT SPECIFIC GRATE LOCATIONS
- GAS INFRA-RED RADIANT DESIGN FOR CLEAN, EFFICIENT AND EXTREMELY FAST HEAT-UP
- 8" WIDE CAST COOKING GRATE SECTIONS PROVIDE PRODUCT SUPPORT AND BRANDING FOR THAT EVER IMPORTANT EYE APPEAL
- SANITARY DESIGN, ALL WELDED, ALL STAINLESS STEEL CONSTRUCTION
 - ** CLEANING IS A BREEZE **
- AVAILABLE IN FOUR STANDARD MODELS (26", 34", 42", AND 50" WIDTH)

NO BROILER CAN BOAST ALL OF THESE TRULY UNIQUE FEATURES

"The Quest for the Best Ends at Quest"

MODEL	WIDTH (mm)	DEPTH (mm)	BODY HEIGHT (MM)	BTU's	GAS LINE	GRID SIZE		SHIPPING WT	
						SQ IN.	SQ CM	LBS	KGS
QBD 26	26" (660)	31" (790)	12" (305)	75,000	3/4" (19)	624	(4025)	240	(110)
QBD 34	34" (865)	31" (790)	12" (305)	105,000	3/4" (19)	832	(5365)	305	(140)
QBD 42	42" (1065)	31" (790)	12" (305)	135,000	3/4" (19)	1040	(6710)	365	(170)
QBD 50	50" (1270)	31" (790)	12" (305)	165,000	3/4" (19)	1248	(8050)	430	(195)

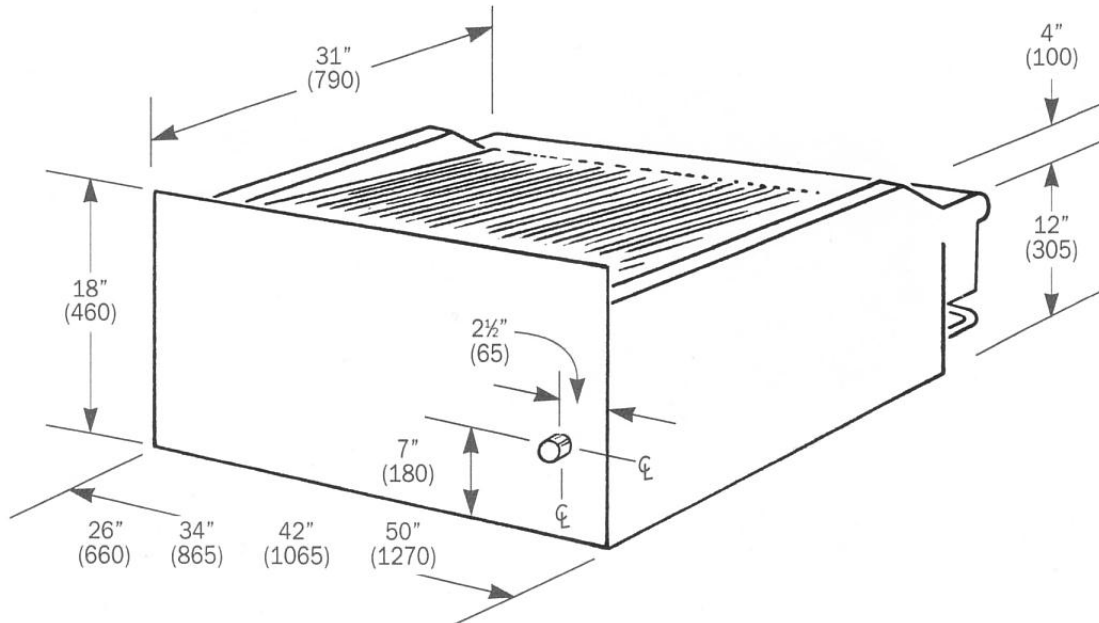

OPTIONAL BASE

The low profile (12" - 305 mm) of the Quest Char Broiler frees-up valuable storage space beneath the unit. All varieties of Quest modular bases can be used with QBD broilers.

An optional refrigerated base can be supplied to ensure that a fresh supply of broiler menu items are always close at hand. The base unit is available with drawers and/or doors to fit all sizes of broilers.

CLEANING AND MAINTENANCE

Most interior and exterior surfaces, including front panel, splashback and inside liner, are stainless steel. The unit dismantles easily for cleaning. The stainless steel radiants are removable and have been designed to protect the burners from dripping grease.

Grease run-off from the grid is collected in a slide-out grease can which is well shielded from direct heat.

INSTALLATION NOTES

- Specify natural gas or propane.
- Unit requires 6" (150 mm) clearance from combustible walls at back and 3" (75 mm) at sides.
- 3/4" (19 mm) gas connection at rear (ideal for gas hose connection).

NOTE: Dimensions shown are accurate at time of printing but subject to change without notice. If sizes are critical, consult your Russell representative or the factory.



Quest METAL PRODUCTS LIMITED

949 Erin St., Winnipeg, Manitoba R3G 2W6
Tel: (204) 786-2403 Fax: (204) 783-7598

Distributed in Canada by:

RUSSELL Food Equipment

Victoria / Vancouver / Edmonton / Calgary / Regina
Saskatoon / Winnipeg / Thunder Bay / Sault Ste. Marie
Toronto / London / Windsor / Ottawa / Montréal / Halifax

A3 135 995

PRINTED IN CANADA